

SERIES S 20-0.1 | LINE REGULATOR

- Diaphragm single stage
- Purity up to 6.0
- Inlet pressure:
50 bar (725 psi)
- Outlet pressure:
0,01 - 0,1 bar
0.14 - 1.45 psi

- ★ Very low outlet pressure
- ★ 2 inlets /2 outlet
- ★ Rear inlet
- ★ Rear threads for panel mounting
- ★ High accuracy due to large diaphragm
- ★ O₂ application compatible (see technical data)

Special requirements on request



Rear inlet view

APPLICATIONS

- The Series S 20-0.1 is used as a line regulator for lab applications requiring a low outlet pressure less than 100 mbar (1.45 psi).

KEY FEATURES

- With the rear threads, it can be used for wall mounting.

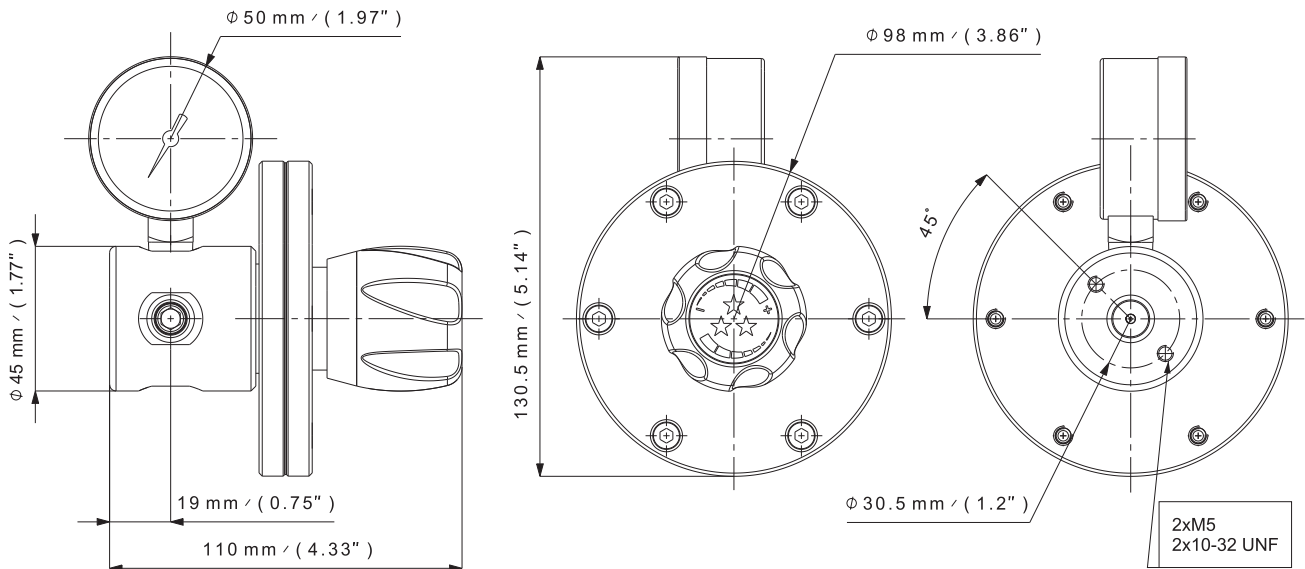

SPECIFICATIONS

Female ports	G 3/8 or 1/4 NPT (inlet/outlet)	Weight	± 0,6 kg ± 1.32 lbs	Inlet pressure	50 bar 725 psi
Seat seal	EPDM	Leak rate	10 ⁻⁸ mbar ℓ/s He	Outlet pressure	0,01 - 0,1 bar 0.14 - 1.45 psi
O-ring	EPDM - Standard FPM	Temperature range	- 20°C to + 60°C - 4°F to + 140°F	Nominal Flow	0,5 Nm ³ /h (N ₂)
Diaphragm	AISI 304	Gauges	Low pressure (M10 x 1 or 1/4 NPT)	Oxygen use	inlet pressure ≤ 30 bar max. for brass and stainless steel

FLOW CURVES

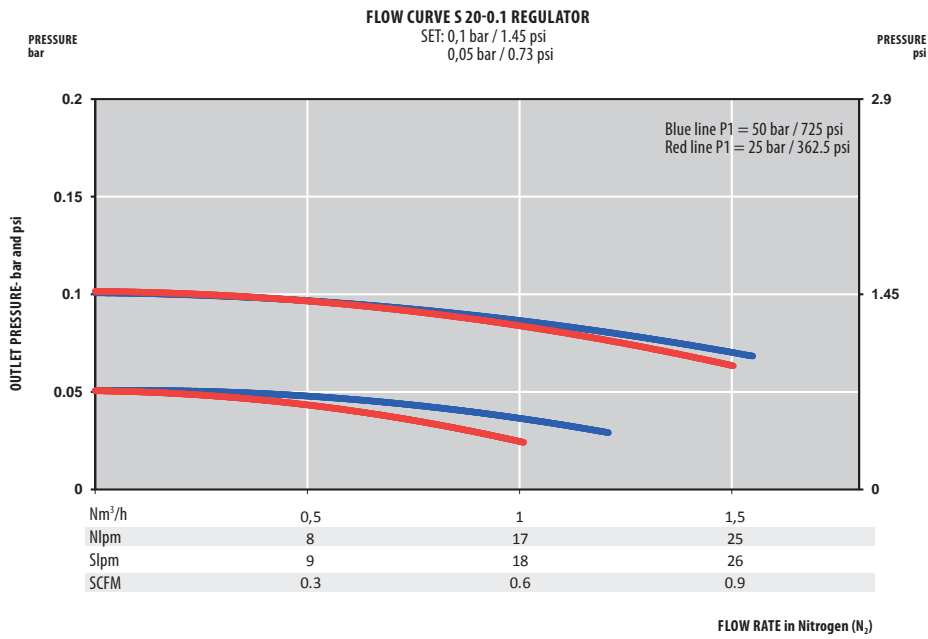

PRODUCT CONFIGURATOR

S	Body Material		End Connections		O-ring Material	Gauges	Ports Configuration		
	L	20	0.1	G	EPDM	1	A		
	Chrome plated brass	L		G 3/8 - G 3/8	EPDM - Standard	With	1	Standard Configuration	A
	Stainless steel	I		1/4 NPT - 1/4 NPT	FPM			Reverse inlet/outlet	R